

PROCESSPOWER®

UPS System



The Digital PROCESSPOWER (DPP) UPS from AMETEK Solidstate Controls is a true on-line, double conversion Uninterruptible Power Supply system that provides continuous, clean, regulated power for critical AC loads. Designed specifically for process control and industrial applications, the DPP systems utilize state of the art PWM technology, incorporating high power IGBT semiconductors, and digital control for enhanced communications, monitoring, control and diagnostics capabilities. Also essential to the DPP design is the use of fiber optic cables for control and communications; allowing for better isolation and faster, more accurate signals between processors. The DPP designs also include an LCD panel and user-friendly touch screen display for the ultimate in User control.

Industrial PWM Uninterruptible Power Supply System

Three Phase 10-125 kVA

The Purpose of our business is to provide continuity of electrical power to keep businesses in business.



*The Columbus, Ohio facility
is ISO 9001 Certified*

World Headquarters

875 Dearborn Drive - Columbus, OH 43085
Phone: 1-614-846-7500 1-800-635-7300
Fax: 1-614-885-3990

Latin American/South American Headquarters

Olive 1954 2000 Rosario, Argentina
Phone: +54-341-455-3332
Fax: +54-341-454-0142

Asia Pacific Headquarters

AMETEK Singapore Office
Solidstate Controls
43 Changi South Ave 2 #04-01
Singapore 486164
Phone: 65-6484-2388 Fax: 65-6481-6588

Mexico Office

Calle Lago Meru
No.32 3rd Floor
Mexico City, Mexico 11520 D.F.
Phone: +52-555-250-1232
Fax: +52-555-250-7981

Visit our websites:

English: www.solidstatecontrolsinc.com **-Nuclear:** www.nuclearups.com **-Spanish:** www.solidstatecontrolsinc-esp.com
Russian: www.solidstatecontrolsinc-ru.com **Chinese:** www.solidstatecontrolsinc-chn.com
Brazilian Portuguese: www.solidstatecontrolsinc-bz.com

THE POWER BEHIND THE PROCESS

PROCESSPOWER UPS System

LCD and Touch Screen User Interface Panel



Shown with optional indicator lights

Keypad Controls and Switches

Float/Equalize Initialization w/Light
 Battery Test Initialization
 Inverter to Load w/Light
 Bypass to Load w/Light
 Static Switch Reset Retransfer
 Latching Alarm Reset
 Audible Alarm Silence
 Display On
 Inverter Enable (On/Off) Switch

Standard Mimic Screen (LCD Panel) Indicators

Equalize Time Remaining
 Charger Status (OK/Fail)
 Float/Equalize Status
 Inverter Status (OK/Fail)
 Synchronism Status (In/Out of sync)
 Static Switch Position (Inverter or Bypass)
 Manual Bypass Position (Inverter or Bypass)
 Bypass Status (OK/Fail)

Standard LED Indicators

UPS Normal
 UPS Trouble

General Specifications-Standard Features

Circuit Breakers

AC Input (14kAIC)
 Battery Input (10kAIC, min.)
 Bypass Input (14kAIC)

Metering (Displayed on Mimic Screen)

DC Bus Voltage
 DC Bus Current (\pm)
 AC Output Voltage
 AC Output Current
 AC Output Frequency
 Rectifier Output Current

System Measurements (Displayed on Mimic Screen)

Total Number of Battery Discharges
 Total Operational Time on Batteries
 Average Time on Battery per Discharge
 Historical Min/Max Battery Voltage

System Measurements

(Displayed on Mimic Screen)-continued

Recent Min/Max Battery Voltage
 Total Operation Time on UPS
 Total Operation Time on Bypass
 Total Operation Time on Inverter

Alarms

(Displayed on LCD Alarm Panel)

Fan Failure
 Charger Failure
 Low DC Voltage
 Low DC Disconnect
 Battery Breaker Open
 ST/SW Retransfer Blocked
 Battery Discharging
 Inverter Bridge Over Temperature
 IGBT Desaturation
 Overload Shutdown
 Bypass Supplying Load
 ST/SW Bridge Over Temperature

Alarms (Displayed on

LCD Alarm Panel)-continued

ST/SW SCR Failure
 Bypass Failure
 Inverter Failure

System Diagnostics

(Displayed on LCD Alarm Panel)

Loss of System Communication(s)
 Power Supply Failure(s)

Relay Controls

The following alarms also include 1 set of normally open and normally closed relay contacts rated for 120 VAC @3 amps:
 UPS Trouble (Summary)
 Bypass Supplying Load
 UPS Communications Failure (Summary)

General Specifications-Optional Features

Metering and System Measurements

AC Input Power (Voltage and Current)
 Inverter Output Voltage
 Bypass Input Voltage
 Output Power (kVA, KW, Power Factor)
 Bypass Input Frequency
 % Inverter Loading

Circuit Breaker

65 KAIC AC Input and Bypass Input
 Inverter Output (non-Automatic)
 AC Output

Alarms

Charger Overload
 High DC Disconnect
 Pos/Neg to Ground

Alarms-continued

High/Low Bypass Source Voltage
 High/Low AC Output Voltage
 AC Input Failure
 AC Output Overload
 High/Low Inverter Output Voltage
 Out-Of-Sync
 Inverter Fuse Blown
 Inverter Off Frequency
 Bypass Off Frequency
 Static Switch Fuse Blown
 Battery Near Exhaustion
 Rectifier/Charger Fuse Blown
 Low AC Input Voltage
 High DC Voltage
 Rectifier/Charger Failure
 MBS to Bypass
 AC Input CB Open
 Bypass Input CB Open
 AC Output CB Open

Misc

External MBS
 Rectified Configuration
 Cascade and Parallel Redundant Configuration
 10% Reflected Harmonics (Rectifier Input)
 Additional LED Indicators
 Additional Relay Contacts
 Latching Alarms
 Lamp test
 ESI (Essential System Indicator) Panel
 Alarm Test

Communications

Modbus RTU
 SNMP Compatible

General Specifications-Performance Features

Battery Charger/Rectifier

· AC Input	
Nominal Voltage*	600, 380, 415, 480: 3-Phase/3-Wire
Input Range	± 10%
Frequency	50 or 60 Hz ± 5%
· DC Output	
DC Bus Voltage(s)	110, 120, 220, 240, and 360 VDC
Regulation	± 1%
Ripple Voltage	<2% with battery connected
Capacity	Sized to recharge a thirty (30) min. battery to 95% of its rated capacity within eight (8) hours, while simultaneously supplying power to a fully loaded inverter
Float/Equalize	± 5% Adjustability

Inverter

· DC Input	
Nominal Voltage	110V/55 (96-128VDC)
Range/ # of Cells	120V/60 (105-140VDC)
(Lead Calcium Type)	220V/110 (192-256VDC)
	240V/120 (210-280VDC)
	360V/180 (315-419VDC)
Battery End Voltage	1.75 end volts per cell
(Lead Calcium Type)	
· AC Output	
Inverter/UPS Ratings	10-125 kVA
Power Factor	0.8 – 1.0
AC Output voltage*	120/208, 22/380, and 277/480
	3-phase, 4-wire
Regulation	± 1%
Voltage Adjustment	± 5%
Frequency	50 or 60 Hz; ± 0.1%
Crest Factor	3:1
Total Harmonic Distortion (THD)	100% linear load <3%
	100% non-linear load <5%
Transient Response	± 5% (0-100% load)
Recovery Time	< 50 msec to ± 1%
Overload Capacity	100% - continuous
	125% - 10 minutes
	150% - 1 minute

*Custom Input and Output Voltages available-consult factory

Reliability for Critical Industrial Applications



Oil Platforms



Process Control



Petrochemical

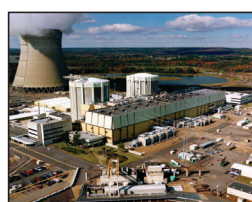

Power Generation

Static Switch

Bypass Voltage	120/208, 220/380, 277/480
	3-phase, 4-wire
Switch Type	Inversely paired set of SCRs (one set per leg)
Failure Mode	Automatically fails to Bypass
Transfer Time	Make Before Break:
Sync Capture Range	0.5% to 1.5%
Slew Rate	1Hz/sec to 10Hz/sec (adjustable)
Overload Capability	125% continuous; 150% for 10 minutes; 200% for 1 minute; 1000% for 1 cycle

Manual Bypass Switch

Voltage	120,280, 220/380, and 277/480 3-phase, 4-wire
Mounting	Inside UPS/Inverter Enclosure
Positions	Two
Construction	Electro-Mechanical Rotary Type
Transfer Time	Make Before Break
Overload Capacity	125% continuous; 150% for 10 minutes; 200% for 1 minute; 1000% for 1 cycle

Environmental

Ambient Temperature	-5 to 40°C (23 to 104°F)
Relative Humidity	0-95% non-condensing
Operating Altitude	0-3300 meters (10,000 feet)
Audible Noise	65-72dB(A) @ 1.5 meter typical
Addition of drip shield may	increase the noise by 1-3dB (A) typical
Cooling	Aided Convection or Forced Air, depending on kVA rating and design

Cable Entry

Top or Bottom Entry Standard

Mean Time Between Failure (MTBF)

> 140,000 Hours

Cabinet Rating

Nema 1 (IP-20) (other enclosure ratings available-consult factory)

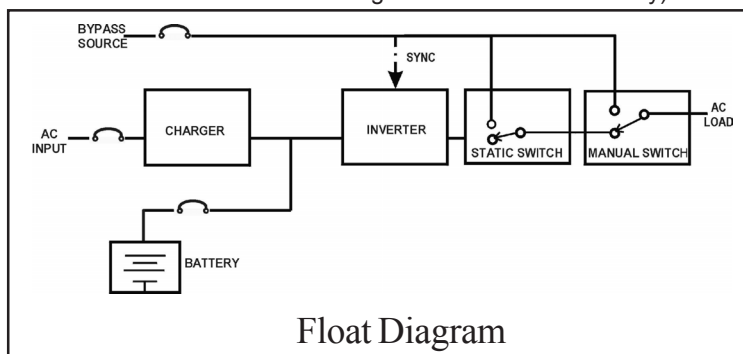

Float Diagram

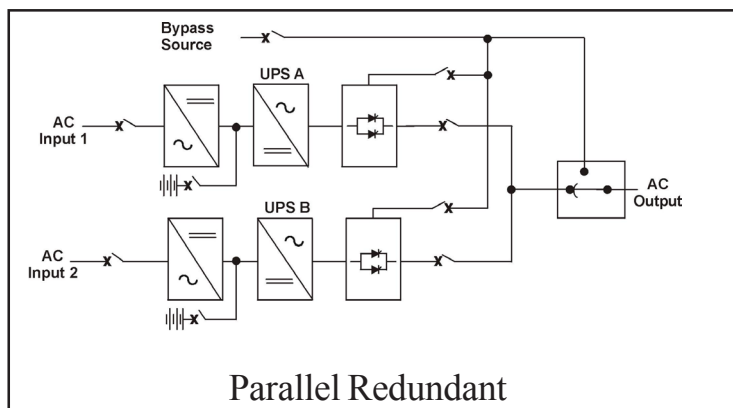

Parallel Redundant

**0.8 Output Power Factor
120 VDC (60 Lead Calcium Battery Cells)**

Model	Rated Output Power		Efficiency		3PH AC Input/Freq AC Amps per Phase*			DC Current*	3PH AC Output Amps Per Phase*			UPS Cabinet Style	Weight		Heat Loss (Watts)
	kVA	kW	AC-DC	DC-AC	480/60	600/60	380/50	1.75 VPC	480	208	380		Lbs.	Kg.	
3DPP010-**-**	10	8	92%	87%	21	17	26	88	12	28	15	GTD1X	1100	499	1995
3DPP015-**-**	15	12	92%	87%	30	24	39	131	18	42	23	GTD1X	1300	590	2993
3DPP020-**-**	20	16	93%	87%	40	32	50	175	24	56	30	GTD1X	1500	680	3775
3DPP030-**-**	30	24	93%	87%	59	47	75	263	36	83	46	GTD2X	1950	885	5663
3DPP040-**-**	40	32	93%	87%	78	62	99	350	48	111	61	GTD2X	2050	930	7550
3DPP050-**-**	50	40	93%	87%	99	79	125	438	60	139	76	GTD3X	2150	975	9438

240 VDC (120 Lead Calcium Battery Cells)

Model	Rated Output Power		Efficiency		3PH AC Input/Freq AC Amps per Phase*			DC Current*	3PH AC Output Amps Per Phase*			UPS Cabinet Style	Weight		Heat Loss (Watts)
	kVA	kW	AC-DC	DC-AC	480/60	600/60	380/50	1.75 VPC	480	208	380		Lbs.	Kg.	
3DPP030-**-**	30	24	93%	89%	58	46	73	128	36	83	46	GTD1X	1950	885	4996
3DPP040-**-**	40	32	94%	89%	76	61	97	171	48	111	61	GTD2X	2050	930	6250
3DPP050-**-**	50	40	94%	89%	96	77	121	214	60	139	76	GTD2X	2150	975	7813
3DPP060-**-**	60	48	94%	89%	119	95	151	257	72	167	91	GTD2X	2550	1157	9375
3DPP080-**-**	80	64	94%	89%	153	122	193	342	96	222	122	GTD3X	3400	1542	12500
3DPP100-**-**	100	80	94%	89%	191	153	241	428	120	278	152	GTD4X	4400	1996	15625
3DPP125-**-**	125	100	94%	89%	238	190	301	535	150	348	190	GTD4X	4900	2227	19531

**1.0 Output Power Factor
120 VDC (60 Lead Calcium Battery Cells)**

Model	Rated Output Power		Efficiency		3PH AC Input/Freq AC Amps per Phase*			DC Current*	3PH AC Output Amps Per Phase*			UPS Cabinet Style	Weight		Heat Loss (Watts)
	kVA	kW	AC-DC	DC-AC	480/60	600/60	380/50	1.75 VPC	480	208	380		Lbs.	Kg.	
3DPP010-**-**	10	10	92%	87%	30	24	39	109	12	28	15	GTD1X	1300	590	2494
3DPP015-**-**	15	15	92%	87%	40	32	51	164	18	42	23	GTD1X	1500	680	3539
3DPP020-**-**	20	20	93%	87%	60	48	76	219	24	56	30	GTD2X	1950	885	4719
3DPP030-**-**	30	30	93%	87%	81	65	102	328	36	83	46	GTD2X	2050	930	7078
3DPP040-**-**	40	40	93%	87%	99	79	125	438	48	111	61	GTD3X	2150	975	9438

240 VDC (120 Lead Calcium Battery Cells)

Model	Rated Output Power		Efficiency		3PH AC Input/Freq AC Amps per Phase*			DC Current*	3PH AC Output Amps Per Phase*			UPS Cabinet Style	Weight		Heat Loss (Watts)
	kVA	kW	AC-DC	DC-AC	480/60	600/60	380/50	1.75 VPC	480	208	380		Lbs.	Kg.	
3DPP030-**-**	30	30	93%	89%	77	62	98	161	36	83	46	GTD2X	2050	930	5859
3DPP040-**-**	40	40	94%	89%	96	77	121	214	48	111	61	GTD2X	2150	975	7813
3DPP050-**-**	50	50	94%	89%	119	95	151	268	60	139	76	GTD2X	2550	1157	9766
3DPP060-**-**	60	60	94%	89%	153	122	193	321	72	167	91	GTD3X	3400	1542	11719
3DPP080-**-**	80	80	94%	89%	191	153	241	428	96	222	122	GTD4X	4400	1996	15625
3DPP100-**-**	100	100	94%	89%	238	190	301	535	120	278	152	GTD4X	4900	2227	19531

*Circuit Breakers are sized at a minimum of 125% of rated current

Specifications subject to change without notice

"DD"		"EE"		"FF"		"GG"		"HH"		"I"		"J"	
AC Input Volts	Code	DC Bus Volts	Code	AC Output Volts	Code	Freq.	Code	Output P.F.	Code	Charger Design	Code	UPS Config	Code
480	48	120	12	208	20	60	60	0.8	K	6-Pulse	S	Float	F
600	60	240	24	480	48	50	50	1.0	W	12-Pulse	T	Cascaded	C
380	38	360	36	380	38								

**A complete model number includes the AC input voltage, DC bus (link) voltage, AC output voltage, system frequency, output power factor, and UPS configuration. To "build" a model number, use the "code" in the matrix shown above, following the example format: 3DPP010-DD-EE-FF-GG-H-I-J; where DD=AC Input Voltage; EE=DC bus Voltage; FF=AC Output voltage; GG=system Frequency; H=Output Power Factor ('K' for 0.8; 'W' for 1.0); I=6 (S) or 12 (T) Pulse Charger design; J=UPS configuration ('F' for Float, 'C' for Cascaded Redundant.)

Inches--Cabinet-Dimensions--mm

For Example: A 20 kVA with 480 volt input; 120 VDC bus voltage; 208 volt output; 60 Hz; 0.8 output power factor; 6=pulse charger; Float system would have the following model number:
3DPP020-48-12-20-60-K-S-F.

Style	H	x	W	x	D	H	x	W	x	D
GTD1X	79	x	32	x	36	2007	x	813	x	914
GTD2X	79	x	54	x	36	2007	x	1372	x	914
GTD3X	79	x	86	x	36	2007	x	2184	x	914
GTD4X	79	x	108	x	36	2007	x	2743	x	914

For custom systems, and for units which do not have a configurable model number, insert a 'C' in the model number as follows: 3DPP020C.

Certain optional features and/or combinations may require larger cabinets.
Contact factory