

TABLE of CONTENTS

SE^{Plus} SPECIFICATION

Section	Description	Page No.
1.0	Introduction	1
2.0	Applicable Standards, Codes and Regulations	1
3.0	Environmental Conditions	1
4.0	System Description	2
5.0	System Operation	2
5.1	Normal	2
5.2	Loss of Main Power	2
5.3	Recharge	2
5.4	Float/Equalize	3
5.5	Bypass	3
5.6	Load Transfer	3
5.7	Manual Bypass	3
5.8	System Start-Up	4
5.9	System Shut-Down	4
5.10	Load Transfer	5
6.0	Rectifier/Charger	5
6.1	General	5
6.1.1	Optional Rectifier Configuration	5
6.2	Capacity	5
6.3	Input Voltage	5
6.4	Input Power Factor	5
6.5	Output Voltage	5
6.6	Voltage Regulation	6
6.7	Output Ripple	6
6.8	Current Limit	6
6.9	Float Adjustment	6
6.10	Equalize Adjustment	6
6.11	Float/Equalize Timer	6
6.12	Isolation	6
6.13	Rectifier/Charger Operation	7

7.0	Static Inverter	7
7.1	General	7
7.2	Output Voltage	7
7.3	Input Voltage	7
7.4	Voltage Regulation	7
7.5	Frequency Regulation	8
7.6	Frequency Control	8
7.7	Load Power Factor	8
7.8	Harmonic Distortion	8
7.9	Crest Factor	8
7.10	Slew Rate	8
7.11	AC Transient Response	8
7.12	AC Transient Recovery	9
7.13	Overload Capability	9
7.14	Over Temperature	9
7.15	DC Input Transient	9
8.0	Static Transfer Switch	10
8.1	General	10
8.2	Operation	10
8.3	Transfer Time	10
8.4	Transfer Point	11
8.5	Auto-Transfer Defeat	11
8.6	Fail-Safe Design	11
8.7	Overload Rating	11
9.0	Manual Bypass Switch	11
9.1	Mounting	11
9.2	Configuration	11
9.3	Overload Rating	12
10.0	Accessories	12
10.1	Controls	12
10.2	Meters	12
10.3	Mimic Panel/Indicator Lights and Alarms	13
10.4	Optional Indicators and Alarms	15
10.5	Optional Serial Communications Port	18
10.6	Overload Protection	19

11.0	General Requirements	20
	11.1 System Efficiency	20
	11.2 Audible Noise	20
	11.3 Cooling	20
	11.4 Wiring	20
	11.5 EMI Suppression	20
	11.6 Control Power Supply	20
	11.7 Transformers	21
	11.8 Nameplate Markings	21
12.0	Mechanical Specification	21
	12.1 Enclosure	21
	12.2 Ventilation	22
	12.3 Cable Entry	22
	12.4 Power Connections	22
	12.5 Parts Placement	22
	12.6 Wire Supports	22
	12.7 Wire Marking	22
	12.8 Component Marking	23
	12.9 Personnel Safety	23
	12.10 Painted Surfaces	23
13.0	Shop Testing	23
14.0	Documentation	23
	14.1 Outline Drawings	23
	14.2 Schematic Drawings	24
15.0	Preparation for Shipment	24

SE^{Plus} Series UPS Product Specification

1.0 INTRODUCTION

This specification describes a continuous duty, solid-state, on-line, Uninterruptible Power Supply (UPS). This means that under normal operating conditions, power is provided to the load through the inverter. AC power is converted to DC power by a rectifier/charger section, which provides power to operate the inverter and keep the batteries fully charged. The inverter then converts the DC power back to clean, conditioned AC power. The UPS shall operate in conjunction with the existing building/plant electrical systems to provide high quality power to the critical load. The system shall consist of an integrated Rectifier/Charger, Inverter, Static Transfer Switch, and Manual Maintenance Bypass Switch.

2.0 APPLICABLE STANDARDS, CODES AND REGULATIONS

Unless noted otherwise, the design, fabrication, testing, and performance of the system shall be in accordance with the latest revisions of the following industry/agency standards and codes, where applicable:

National Electrical Manufacturers Association (NEMA)
American National Standards Institute (ANSI)
National Electric Code (ANSI/NFPA 70)
Institute of Electrical and Electronic Engineers (IEEE)
International Electrotechnical Commission (IEC)
UL-1778 (C-UL)

3.0 ENVIRONMENTAL CONDITIONS

3.1 Operating Temperature

The system shall operate at rated output without any adverse affects in an ambient temperature of 0°C to 40°C (32° F to 104° F), except batteries.

3.2 Relative Humidity

The system shall operate at a relative humidity of 5% to 95% non-condensing for a temperature range of 10°C to 40°C.

3.3 Operating Altitude

The system shall operate at any altitude from sea level up to 2500 meters (8,200ft) above sea level without de-rating.

4.0 SYSTEM DESCRIPTION

4.1 The UPS system shall be of the float configuration type. During any interruption of the AC power input to the UPS, the battery bank shall continue to provide input DC power to the inverter with no interruption in inverter output AC power.

4.2 Each U.P.S. system, as a minimum, shall consist of the following major components:

- AC Rectifier/Charger
- Static Inverter
- Static Transfer Switch (Zero Break)
- Manual Bypass Switch
- Battery Bank

5.0 SYSTEM OPERATION

5.1 Normal

The critical load is continuously supplied by the inverter, with isolated clean AC power. The rectifier/charger derives its power from the commercial AC source and supplies DC power to the inverter while simultaneously float charging the battery. Under normal input to the rectifier/charger, the battery bank may be disconnected from the system without affecting the inverter output.

The inverter output shall maintain phase with the bypass source. If the bypass source deviates more than $\pm 0.5\%$ of (50 or 60 HZ) the inverter output shall run on its own internal oscillator until the reference source returns to within acceptable limits.

5.2 Loss of Main Power

Upon failure of the commercial AC power, the critical load shall continue to be supplied by the inverter without any interruption; the inverter obtains its power from the storage battery. There shall be no interruption of power to the critical load upon failure or restoration of the commercial source. The inverter frequency shall revert to the internal oscillator.

5.3 Recharge

Upon restoration of the commercial AC power (provided a Low DC Disconnect has not occurred) the rectifier/charger shall recharge the batteries and simultaneously supply DC power to the inverter. If a Low DC Disconnect has occurred, a manual reset of the Inverter's DC input breaker must be performed.

5.4 Float/Equalize

Upon pressing the equalize push-button, the charger shall automatically initiate the equalize voltage for the pre-set time on the equalize timer.

Pressing the float push-button any time during the equalize mode shall return the charger to the float voltage.

5.5 Bypass

During an overload or load fault at the inverter output, the static switch shall automatically transfer the load onto commercial power (transfer point factory set @ 120% of rated load) without interruption.

On clearing an inverter malfunction, fault or overload condition, the static transfer switch shall automatically transfer the UPS load from the bypass to the inverter output. The transfer from both directions shall be without interruption (zero-break). A static switch transfer can only be accomplished when the inverter output is in sync with the bypass source (except during inverter failure).

Transfer to the bypass may also be accomplished manually by the Bypass to Load push button without interruption. This shall lockout the auto retransfer function.

Upon the deterioration or failure of the inverter bridge output, the load shall transfer to the bypass without any interruption.

5.6 Load Transfer

Pressing the Bypass to Load push button while the inverter is supplying the load, will cause the static switch to transfer the load onto the bypass source if the bypass source is available and it is in sync with the inverter. The operation of the Inverter to Load push button is the same as the Bypass to Load push button except that it transfers the load to the inverter.

5.7 Manual Bypass

During maintenance, the system may be bypassed without interruption to the load for ease of inspection.

5.8 System Start-Up

- Press the pre-charge button (provided on units 20 kVA and larger) until the pre-charge LED is lit.
- Close the Battery Input Circuit Breaker while the pre-charge LED is ON. This will start the inverter.
- Close the Rectifier/Charger AC Input Circuit Breaker.
- If the optional rectifier/charger DC Output Circuit Breaker has been included, close that breaker now.

At this point a check of the DC Output Voltmeter can be made to insure that the rectifier/charger is operating at the correct voltage. Once the inverter is running, the Inverter Output Voltmeter and Frequency Meters can be checked for correct readings

- Close the Bypass Source AC Circuit Breaker.

As soon as the inverter output is synchronized with the bypass source, the “In-Sync” LED will light. (Note: If the Auto-Retransfer switch is in the “ON” position, the static switch will automatically transfer the load onto the inverter).

- Verify that the static switch is in the “Bypass To Load” position, and transfer the manual bypass switch to the “NORMAL” position.
- Press ‘Inverter To Load’ pushbutton.

The inverter is now supplying clean, uninterrupted power to the load.

5.9 System Shut-Down

- Press ‘Bypass To Load’ pushbutton.
- Transfer manual bypass switch to the “Bypass To Load” position.
- Open Bypass Source AC Circuit Breaker
- Open DC Output Circuit Breaker (If Provided with system).
- Open Battery Input Circuit Breaker.
- Open AC Input Circuit Breaker

The load is now being powered by the alternate (or bypass) AC source via the Manual Switch.

5.10 Load Transfer

If the “Bypass To Load” pushbutton is pressed while the inverter is supplying power to the load, the static switch will transfer the load onto the bypass source, provided the bypass source is available, and in-sync with the inverter output. The operation of the ‘Inverter To Load’ pushbutton is the same as the ‘Bypass To Load’ pushbutton, except that it transfers the load onto the inverter.

6.0 RECTIFIER/BATTERY CHARGER

6.1 General

Incoming AC power shall be converted to regulated DC output by the rectifier/charger. The rectifier/charger shall be a constant potential, phase-controlled, (6-pulse) solid-state type with voltage and current control circuitry. The components within the rectifier shall be capable of operating independently from the remaining system.

6.1.1 Optional Rectifier Configuration

As an *option*, when required, a **Rectifier** configuration shall be available. The rectifier shall be provided with a blocking diode to prevent the charging/recharging of batteries. This configuration is used in conjunction with a station battery and battery charger.

6.2 Capacity

The rectifier/charger shall have sufficient capacity to support the total connected load and to recharge the battery at the equalize condition to 90% of full capacity within 8-10 times the discharge rate.

6.3 Input Voltage

The primary AC input voltage shall be 208, 480, 380, 415; or as specified by the user. Input voltage range shall be $\pm 10\%$. Nominal frequency shall be 60 or 50 Hz ($\pm 5\%$).

6.4 Input Power Factor

The input power factor shall be a minimum power factor of 0.75 at nominal input voltage, frequency, and at full-rated load.

6.5 Rectifier/Charger Output Voltage

Nominal Float Voltage: 120 VDC, adjustable $\pm 5\%$

Nominal Equalize Voltage: 140 VDC, adjustable $\pm 5\%$

Note: Based on 60 cell configuration with Lead-Calcium battery; other cell configurations and battery types available)

6.6 Voltage Regulation

The charger output steady state voltage shall not change more than +/-1% (worst case) at the battery bank, for a cable length less than 10 ft., from no load to full-rated load, with input voltage variation of +10% to-10% and input frequency variation of +/-5%. (+10%-15% without discharging the batteries).

6.7 Output Ripple

The output ripple shall be less than 2% RMS when connected to a battery bank having an eight hour, ampere hour rating of at least four (4) times the full load ampere rating of the battery charger..

6.8 Current Limit

The charger shall be capable of supplying 100% rated full load current at float voltage and -10% input. This shall not cause damage to the charger/rectifier, tripping of circuit breakers, or blown fuses. The current limit shall be adjustable from 50% to 100% of rated output.

6.9 Locking Float Adjustment

An internal screw-type adjustment shall be provided to adjust the float voltage +/-5%.

6.10 Locking Equalize Adjustment

An internal screw-type adjustment shall be provided to adjust the equalize voltage +/-5%.

6.11 Float/Equalize Timer

An internal 0-100 Hour electronic timer shall be provided to manually place the charger into a high voltage equalize mode for a specific amount of time and then automatically return it to its normal float mode when the time has elapsed.

6.12 Isolation

A dry type isolation transformer shall be supplied on the input to the rectifier with surge/transient protection on the secondary side.

The delta-wye three phase transformer shall be wound with copper wire and use a UL recognized 200° C insulation system.

An epoxy based insulating varnish shall be applied with a VPI (Vacuum Pressure Impregnation) system to insure a low temperature rise over the 30 year design life of the transformer.

6.13 Rectifier/Charger Operation

The AC input to the Rectifier/Charger shall be insensitive to phase rotation. The AC input shall be completely isolated from the static bypass circuit.

The Rectifier/Charger shall be capable of supplying 66% of its rated load with the loss of one of its three phase inputs.

7.0 STATIC INVERTER

7.1 General

The static inverter shall be a ferroresonant type, which generates single phase AC power. The inverter shall be capable of providing continuous and uninterruptible output power while operating from any DC source within the operating input range.

The inverter bridge shall use power transistors, and Insulated Gate Bipolar Transistors, (IGBTs) to generate the square wave input for the ferroresonant transformer.

7.2 Output Voltage

The inverter's output circuit shall be magnetically isolated from the input circuit and be supplied with a convenient means of grounding or ungrounding the inverter's output.

The inverter's output voltage shall be single phase 2-wire (120 VAC); or 3-wire (120/240 VAC), as specified by user.

The inverter's output voltage shall be maintained for at least 1/2 cycle during an input bridge failure to insure a zero-break static transfer to the bypass source. The inverter's output voltages shall be supplied in standard 50 or 60 Hz values.

7.3 Input Voltage

The maximum DC input voltage shall range from 105-140 VDC while maintaining the specified output voltage.

7.4 Voltage Regulation

The inverter steady state output voltage regulation shall not change more than +/-2% under any of the following conditions:

1. 10 to 100% and 100 to 10% load change.
2. Minimum to maximum DC bus voltage.
3. Minimum to maximum ambient temperature range.

7.5 Frequency Regulation

The free-running, steady state output frequency of the Inverter shall not deviate more than 0.1% due to the following conditions;

1. 10% to 100% load
2. Minimum to maximum DC bus voltage
3. Minimum to maximum ambient temperature

7.6 Frequency Control

The output frequency of the inverter shall be controlled by a crystal controlled oscillator, which can be operated as a free-running unit or as a slave for synchronized operation with a separate AC source. The inverter shall track the AC reference source provided it is 50 60 (+/-0.5%) Hz. Upon failure or excessive frequency deviation of the reference the oscillator shall automatically revert to its free-running mode.

7.7 Load Power Factor

The inverter shall be capable of handling linear loads of 0.8 pf -1.0 pf while maintaining +/-2% regulation and non- linear loads (switch-mode power supplies) with a power factor range of 0.7 to 1.0. All testing and verification shall be conducted with a Harmonic, rather than Displacement PF type load.

7.8 Harmonic Distortion

The inverter shall limit the total harmonic distortion of the output voltage to less than 5% RMS total with a 100% linear load; less than 7.5% THD with a 100% switch-mode type load.

7.9 Crest Factor

The inverter shall be capable of supplying non-linear loads exhibiting a crest factor of up to 3.0 at full load without additional filtering or increasing the size of the system.

7.10 Slew Rate

The inverter frequency rate of change shall not exceed 1 Hz/second when synchronizing to the bypass reference.

7.11 AC Transient Response

The inverter voltage transient response shall not exceed +8% to -10% due to a 100%-50% or 50%-100% step load change. During a 100% step load the worst case maximum deviation shall be a *momentary* (-) 23% in the first half cycle.

7.12 AC Transient Recovery

The output voltage, following the step load changes listed above, shall return to within +/-2% of the steady state output voltage within 50 milliseconds (3 cycles).

7.13 Overload Capability

The inverter shall be capable of supplying loads up to 120% of the rated load continuously. The inverter shall current limit at approximately 175 - 200% of rated load, and supply up to 500% rated current for approximately one cycle.

7.14 Over Temperature

Upon heat sink over temperature, the U.P.S. shall automatically transfer the load to the bypass source. If the over temperature occurs for more than 60 seconds, the DC/battery input breaker shall trip protecting the inverter bridge from damage. Manual re-transfer of the load onto the inverter shall be permitted when the temperature returns to normal.

7.15 DC Input Transient

The DC input shall include an input filter to suppress externally generated DC transients and to control inverter switching transients at the battery. Filtering shall be designed to suppress a transient of 4000 volts, with a 10 micro second duration, occurring at the inverters DC input terminals.

8.0 STATIC TRANSFER SWITCH

8.1 General

The static switch shall be a naturally commutated, high speed transfer device provided as an integral part of the U.P.S. The control of the unit shall provide an automatic or manual uninterrupted transfer of the load to the bypass.

The static switch shall use inverse parallel connected 600 volt silicon controlled rectifiers with an ampacity suitable to carry ten times the inverter's capacity for one cycle.

8.2 Operation

The static switch shall automatically connect the bypass source to the critical load and have the following features:

- Uninterrupted Transfer - The static switch shall automatically transfer the critical load after the control logic senses one of the following conditions:
 1. Inverter Failure
 2. Inverter Overcurrent
 3. Inverter Output Over/Under Voltage (+/-10%) >16 msec.
 4. Low DC Disconnect
 5. Manual Transfer via front panel push button
- Uninterrupted Automatic Retransfer - If the transfer control switch is set for automatic retransfer, the control circuit shall be capable of retransferring the critical load to the inverter output when the overload is removed and the inverter output is within specification.
- Uninterrupted Manual Retransfer - If the transfer control switch is set for manual retransfer, upon manual command the critical load shall be transferred to the inverter.
- Transfer Lockout - The transfer logic shall not allow a transfer to the bypass source if one of the following conditions exist:
 1. Bypass source out of sync with inverter output (Except for upon inverter failure or low DC disconnect.)
 2. Bypass source not available

8.3 Transfer Time

The transfer time of the static switch shall be zero, resulting in an uninterrupted flow of power to the system loads.

8.4 Transfer Point

The static switch current sense transfer point shall be adjustable from 100% to 125%, factory set at 120%

The current sense shall be designed to prevent premature switching of the static switch with high crest factor loads.

8.5 Auto-retransfer Defeat

An internal switch shall be provided to defeat the automatic retransfer of the static switch after a transfer to the bypass source. Shipment setting for the unit shall be OFF (i.e. auto-retransfer not activated).

8.6 Fail-Safe Design

The static switch shall be designed to fail over to the bypass source. An independent watchdog circuit shall be provided to insure static switch transfer to bypass upon microprocessor failure.

8.7 Overload Rating

The static switch shall be rated for continuous operation at 125% of full rated load; 1000% for one (1) cycle.

9.0 MANUAL BYPASS SWITCH

A manually operated 2-position electro-mechanical bypass switch shall be provided to facilitate system maintenance. In the bypass position, this switch and the static switch input breaker shall isolate the static switch from the bypass source and connect the output directly to the bypass power source.

9.1 Mounting

The manual bypass switch shall be mounted in the system enclosure to reduce interconnect wiring. (As an option, a remote-mounted 3-position switch shall be available.)

9.2 Configuration

The manual bypass switch shall be of a "make-before-break" configuration to ensure absolute continuity of AC power to the critical U.P.S. loads during switch over.

The manual bypass switch shall not require the assistance of the static switch to insure a zero break load transfer.

9.3 Overload Rating

The manual bypass switch shall be rated for continuous operation at 125% of full rated load; 1000% for one (1) cycle.

10.0 ACCESSORIES

10.1 Controls

All controls specified below shall be accessible on the front panel unless otherwise noted.

10.1.1 Inverter to Load

A lighted momentary push button shall be provided to transfer the load to the inverter source.

10.1.2 Bypass to Load

A lighted momentary push button shall be provided to transfer the load to the bypass source.

10.1.3 Float

A momentary push button shall be provided to manually select the float mode on the charger. Note that the **Float** position is the default position.

10.1.4 Equalize

A momentary push button shall be provided to manually select the equalize mode on the charger. The charger will remain in the **Equalize** mode until the pre-set timer times out; or the charger is placed back into **Float** mode by pressing the **Float** pushbutton.

10.1.5 Pre-Charge

DC filter capacitors on 20 KVA systems and larger shall include a current limiting pre-charge circuit, activated by a pushbutton on the front panel of the UPS.

10.2 Meters

At a minimum the front panel shall be equipped with the following 3.5 inch scale analog meters (2% accuracy) for the following functions:

- Inverter Output Voltmeter
- AC Output Ammeter
- Inverter Output Frequency Meter (expanded scale)
- DC Output Voltmeter
- DC Output Ammeter

10.2.1 Optional Meters

Other, *optional* meters shall be available, to include:

- AC Input Voltmeter (1 meter w/switch to monitor each phase)
- System Output Voltmeter
- AC Bypass Input Voltmeter
- Battery Input Voltmeter
- Battery Zero Center Ammeter
- Bypass Source Frequency Meter

10.3 Mimic Panel/Indicator Lights and Alarms

The system shall be equipped with an operational (lighted) mimic panel (See Figure 1.0), displaying the following LEDs. A form "C" contact (SPDT) rated 3 amps@120VAC/28VDC shall be furnished for each specified alarm.

10.3.1 Battery Supplying Load

An indicator (Red) and alarm contact shall be provided to indicate when the battery is supplying power to the load through the inverter (DC bus voltage <127 VDC). The relay shall be normally energized.

10.3.2 Bypass Source Failure

An indicator (Red) and alarm contact shall be provided to indicate when the bypass source has failed. The relay shall be normally energized.

10.3.3 Inverter Supplying Load

An indicator (Amber) shall be provided to indicate when the load is being powered by the inverter.

10.3.4 Low DC Voltage

An indicator (Red) and alarm contact shall be provided when the inverter DC input voltage is less than 120 VDC. The relay shall be normally energized.

10.3.5 Fan Failure

An indicator (Red) and alarm contact shall be provided when any fan has failed. The relay shall be normally de-energized.

10.3.6 In Sync

An indicator (Green) shall be provided when the internal oscillator of the inverter is synchronized to a bypass reference source that is within +/- 0.5 Hz of 60 (or 50) Hz.

10.3.7 Battery Breaker Open Alarm

This alarm shall sense when the Battery Input Breaker is open. An indicator (GREEN) and alarm contact shall be supplied. The relay shall be energized under normal operation.

10.3.8 Static Switch Transfer

An alarm contact (no LED) shall be provided to sense when the inverter is supplying power to the load. The relay shall be normally energized.

10.3.9 Float/Equalize

Indicators (w/o alarm contacts) shall be supplied to indicate the float and equalize modes of the battery charger.

10.3.10 Static Switch Position

Indicators (w/o alarm contacts) shall be supplied to indicate the position of the static switch.

10.3.11 Pre-Charge

An indicator for inverter pre-charge shall be supplied on inverter sizes 20kVA and larger.

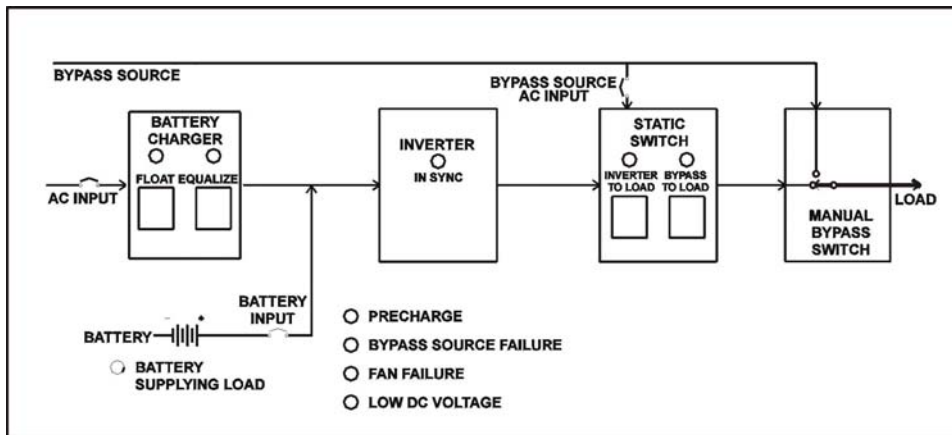

Figure 1.0 Mimic Panel/One-Line Diagram

10.4 Optional Indicating Lights and Alarms

The following **Optional** indicating lights shall be provided on the mimic panel, when required, total number not to exceed the physical limitations of the mimic panel.

10.4.1 High DC Voltage

An indicator (Red) and alarm shall be provided when the inverter input voltage is greater than 144 VDC. The relay shall be normally de-energized.

10.4.2 High DC Disconnect

An indicator (Red) and alarm shall be provided when the Battery Input Breaker has tripped due to High DC Disconnect (DC bus voltage >145 VDC for 5 seconds). The relay shall be normally de-energized.

10.4.3 Negative to Ground

An indicator (Red) and alarm shall be provided when the voltage between positive DC and ground exceeds 65% of nominal output voltage. This alarm is used in conjunction with the Positive DC Ground Detect as a voltage divider. The relay shall be normally de-energized.

10.4.4 Positive to Ground

An indicator (Red) and alarm shall be provided when the voltage between negative DC and ground exceeds 65% of nominal output voltage. This alarm is used in conjunction with the Negative DC Ground Detect as a voltage divider. The relay shall be normally de-energized.

10.4.5 Over-temperature

An indicator (Red) and alarm shall be provided when the ambient temperature is excessive (typically >65°C) . The relay shall be normally de-energized.

10.4.6 AC Available

An indicator (Green) and alarm shall be provided when Commercial AC power is available and present at the charger input. The relay shall be normally energized.

10.4.7 Low AC Output

An indicator (Red) and alarm shall be provided when the AC output voltage is less than 90% of nominal. The relay shall be normally energized.

10.4.8 High AC Output

An indicator (Red) and alarm shall be provided when the AC output voltage is greater than 110% of nominal. The relay shall be normally de-energized.

10.4.9 Reverse Polarity

An indicator (Red) shall be provided when the battery Positive and Negative connections are reversed.

10.4.10 Bypass Source Available

An indicator (Green) and alarm shall be provided when the bypass source is available. The relay shall be normally energized.

10.4.11 Bypass Source Low Voltage

An indicator (Red) and alarm shall be provided when the bypass source is less than 90% of nominal. The relay shall be normally energized.

10.4.12 Bypass Source High Voltage

An indicator (Red) and alarm shall be provided when the bypass source is greater than 110% of nominal. The relay shall be normally de-energized.

10.4.13 AC Input Power Failure

An indicator (Red) and alarm shall be provided when the AC input voltage has failed. The relay shall be normally energized.

10.4.14 UPS Trouble (Summary)

An indicator (red) shall be provided. The alarm status shall activate if any of the alarm conditions specified occur. The relay shall be normally energized.

10.4.15 UPS Trouble (Summary) with Audible Alarm

An indicator (Red), alarm, and audible alarm (front-mounted buzzer) with silence switch shall be provided. The alarm status shall activate if any of the alarm conditions specified occur. The relay shall be normally energized.

10.4.16 Out of Sync

An indicator (Red) and alarm shall be provided when the inverter's internal oscillator is not in synchronization with the bypass source. The relay shall be normally energized.

10.4.17 Inverter fuse Blown

An indicator (Red) and alarm shall be provided when the inverter fuse is blown. The relay shall be normally de-energized.

10.4.18 Static Switch Fuse Blown

An indicator (Red) and alarm shall be provided when the inverter input fuse to the static switch is blown. The relay shall be normally de-energized.

10.4.19 Inverter Available

An indicator (Green) and alarm shall be provided when the inverter output voltage is available and present at the static switch input. The relay shall be normally energized.

10.4.20 Inverter Failure

An indicator (Red) and alarm shall be provided when the inverter is not available to the static switch. The relay shall be normally energized.

10.4.21 AC Power Failure

An indicator (Red) and alarm shall be provided when the AC input voltage to the charger fails. The relay shall be normally energized.

10.4.22 Inverter Low Voltage

An indicator (Red) and alarm shall be provided when the inverter output voltage is less than 90% of nominal. The relay shall be normally energized.

10.4.23 Inverter High Voltage

An indicator (Red) and alarm shall be provided when the inverter is greater than 110% of nominal. The relay shall be normally de-energized.

10.4.24 Push-To-Test Feature

A pushbutton shall be provided to test all LEDs.

10.4.25 Latching Alarm

A latching alarm with reset shall be provided to latch alarms that occur until the reset button is pressed.

10.4.26 Manual Bypass Switch Position Indicator

Two indicators and two SPDT alarm contacts shall be provided to indicate switch position: Normal and Bypass To Load. One alarm relay is energized and the other is de-energized under normal operation.

10.4.27 Low DC Disconnect

An indicator (Red) and alarm shall be provided to indicate when the battery input breaker has been tripped due to low DC disconnect caused by the batter reaching its end of discharge voltage level.

10.5 Optional Serial Communications Port

When specified, an RS-232/RS422 communications interface port shall be provided on the front panel of the UPS, available via a 9-pin D connector. Available information shall include: system status, alarms, and metering.

10.5.1 Communications Format

Baud Rate:	4800 bps
Format:	ASCII data bits, one stop bit
Parity:	None
Duplex:	Full
Handshaking:	Not Required

10.5.2 Connections

RS-232 connections shall be:

Pin 1	Power Ground
Pin 2	TXD (Transmit)
Pin 3	RXD (Receive)
Pin 4	Signal Ground

RS-422 connections shall be:

Pin 1	RXD
Pin 2	RXD
Pin 3	TXD
Pin 4	TXD
Pin 5	Signal Ground
Pin 6	INT (Interrupt)
Pin 7	INT

10.6 Overload Protection

The overload devices shall not be activated when the system is started under normal operating conditions.

10.6.1 AC Input Circuit Breaker

A front access molded case breaker shall be provided for charger/rectifier disconnection and overload protection. The A.I.C. rating of the breaker shall be 10KA minimum.

10.6.2 Bypass Circuit Breaker

A front access molded case breaker shall be provided for Bypass disconnection and overload protection. The A.I.C. rating of the breaker shall be 10KA minimum.

10.6.3 Battery Input Circuit Breaker

A molded case breaker shall be provided for DC input disconnection of both input lines and overload protection. The A.I.C. rating of the breaker shall be 10KA minimum.

10.6.4 Semiconductor Fuses

The semiconductors shall be protected from cascaded failure with special fast acting fuses.

When specified, the following *optional* circuit breakers shall be provided:

- Inverter Output (Non-Automatic)
- AC Output (Static Switch Output)
- Charger DC Output

11.0 GENERAL REQUIREMENTS

11.1 System Efficiency

The overall AC to AC efficiency shall be at least 78-80% depending on KVA size, with the UPS at full rated load and nominal input voltage.

11.2 Audible Noise

The audible noise generated by the unit under rated operating conditions shall not exceed 65 - 72 dBA at a distance of 1.5 meter (typical) from any side of the enclosure and 3 feet above ground. The sound levels shall be measured with the unit operating at rated load, voltage and frequency. Note: addition of a drop/drip shield may increase audible noise by 1-3 dB.

11.3 Cooling

Forced-air cooling shall be provided when necessary to ensure that all components are operating at below their specified operating temperature.

11.4 Wiring

Manufacturer shall utilize NEC, bulletin 70 (US National Electric Code) and NEMA-PE-1 and PE-5 wiring practices where applicable.

Printed Circuit Board control wire shall be 22 AWG UL 3266 cross-linked Polyolefin (XLPE) 300 Volts, 105°C rated.

Control wire and Power wire shall be either SIS or XLPE, depending on the ampacity required.

Power wiring 10AWG through 4/0 AWG shall be SIS UL, CSA listed VW-1, 90°C, 600 V

Power wiring 262 MCM through 777 MCM shall be DLO 90°C, 600 Volt Ethylene Propylene Rubber (EPR) inner jacket, with a Hypalon outer jacket.

All wiring and bus-work shall be copper throughout the system.

11.5 EMI Suppression

Electromagnetic effects shall be minimized to ensure that computer systems, or other similar electronic systems, shall neither adversely affect nor be adversely affected by the system.

11.6 Control Power Supply

The control logic power supply shall incorporate a parallel redundant concept with the inverter DC input and the bypass as a dual source of logic power, to insure control power at all times.

11.7 Transformers

All power transformers or chokes shall be designed using copper windings for reliability and efficiency. The insulation type shall have a temperature rating of at least 200 C (UL 1446, Class N).

An epoxy based insulating varnish shall be applied with a V P I (Vacuum Pressure Impregnation) system to insure a low temperature rise over the 20 year design life of the transformer.

11.8 Nameplate Markings

The nameplate shall be located on the front inside display door and the following minimum information shall be provided on the nameplate:

- a. Model # and Serial #
- b. AC Input Voltage, Phase and Frequency
- c. Rated AC Input Current
- d. Bypass AC Input Voltage, Phase and Frequency
- e. DC Input Voltage and Current
- f. Rated Output Voltage, Amps, Frequency, Power Factor, KVA and KW.

12.0 MECHANICAL SPECIFICATIONS

12.1 Enclosure

The enclosure shall be a NEMA-1(IP-20), free standing, with minimum 12GA framework. Door panels shall be a minimum of 14GA steel and side panels shall be a minimum of 18GA.

The enclosure shall be mounted on channels with a 3 inch lifting base open at the front and back to facilitate moving with a fork lift and to provide an entrance area for air movement through the enclosure.

The enclosure shall be designed with blank plates on the sides and rear for installation against a wall. The equipment shall be designed to allow replacement or maintenance of all components from the front.

One or more hinged doors shall be provided in the front with door locks on each. Hinged panels, 36" and larger, shall be provided with a 2 point latching system for holding the panels securely. Removable covers shall be attached with machine screws.

12.1.1 Drop and Drip Shields

When required, “drop” shields, which protect the enclosure from debris and foreign objects falling into the cabinet; or “drip” shields which protect the enclosure by preventing dripping water from entering the cabinet from above, shall be provided on the top of the enclosure.

12.1.2 Fungus and Moisture Proofing

When specified, a protective coating on components inside the UPS enclosure shall be provided when the unit is installed in environments where the ambient air is extremely humid, or is heavily laden with salt content or other contaminants.

12.2 Ventilation

Air inlets and outlets shall be protected by screens or perforated metal guards to prevent the entrance of a rod having a diameter of 0.5 inches or longer.

12.3 Cable Entry

Cable entry shall be through the top or bottom of the cabinet. On UL units, bottom cable entry is recommended.

12.4 Power Connections

The connections to the AC output or DC input shall be of the stud type and shall be sized for full load service.

Alarm connections shall be sized to allow connection of 12AWG Wire maximum. The alarm terminal boards shall be rated for 300 VAC.

12.5 Parts Placement

The system shall be designed to permit front access to modules, fuses, and assemblies. Parts, test points, and terminals shall be placed so they are accessible for circuit checking, adjustment, and maintenance without removal of any adjacent assembly or component or pose a shock hazard.

12.6 Wire Supports

Permanent wire supports shall be used, no adhesive backed wire supports shall be used.

12.7 Wire Marking

All point-to-point wires shall be marked with a permanent marking system on both ends of each wire.

12.8 Component Marking

All Printed Circuit Boards, indicator lights, meters, controls, semiconductors, and fuses shall be clearly marked with the component designation for ease of serviceability.

12.9 Personnel Safety

The cabinet shall be constructed so that all controls, except float/equalize, are operable with the doors closed, preventing exposure to high voltage terminals. High voltage warning labels shall be visible when any of the cabinet doors are opened.

12.10 Painted Surfaces

All external painted surfaces shall be ANSI 61 Gray enamel with a minimum of 2.0 mil thickness and shall be smooth with no runs, sags, or graininess. All internal mounting plates shall be galvanized steel.

13.0 SHOP TESTING

The system testing shall be in conformance with IEEE 944-1986 section 7.0, and IEC-146-4. Certified test data shall be supplied to verify test results. The manufacturer shall have type-test data available to demonstrate system performance with switch-mode type power supplies.

14.0 DOCUMENTATION

14.1 Cabinet outline and interconnect drawings shall be dimensioned and scaled, and include the following information:

14.1.1 Location of any removable plates for Owner's conduit entry.

14.1.2 Location and size of all terminal blocks for Owner's connections.

14.1.3 Location and size of ventilation openings.

14.1.4 Location of cabinet grounds.

14.1.5 Block diagram including currents for customer cable sizing, breaker locations and sizes, and meter locations.

14.1.6 Size and weight of equipment.

14.1.7 Front panel identification chart.

14.1.8 Nominal heat loss for the specified equipment.

14.2 Schematic type drawings shall include the following information:

14.2.1 System schematics shall include item designations for all electrical components.

14.2.2 Relay contacts diagrams shall be shown in the de-energized position.

14.2.3 Wire sizes and numbers shall have the same designations that appear in the equipment.

15.0 PREPARATION FOR SHIPMENT

15.1 Preparation for shipment shall be in accordance with the manufacturer's standard shipping procedure.

15.2 One complete set of instruction books and "as-built" drawings shall be included with the equipment when shipped.

15.3 To facilitate site access, shipment of individual cabinets, rather than complete lineups, may be necessary.